

## The Home Security Monitoring System with Passive Infrared Receiver, Temperature Sensor and Flame Detector Based on Android System

Novian Patria Uman Putra<sup>1</sup>, Aji Akbar Firdaus<sup>2</sup>, Winarno<sup>3</sup>, Alim Prasaja<sup>4</sup>, Kadek Juni Setiawati<sup>5</sup>

<sup>1</sup>Electrical Engineering, Faculty of Electrical Engineering and Information Technology, Institut Teknologi Adhi Tama, Surabaya, Indonesia

<sup>2,3,4,5</sup>Department of Engineering, Faculty of Vocational, Universitas Airlangga, Surabaya, Indonesia

Email: <sup>1</sup>[novian111190@itats.ac.id](mailto:novian111190@itats.ac.id), <sup>2</sup>[aa.firdaus@vokasi.unair.ac.id](mailto:aa.firdaus@vokasi.unair.ac.id), <sup>3</sup>[winarno@fst.unair.ac.id](mailto:winarno@fst.unair.ac.id), <sup>4</sup>[alimprasaja@gmail.com](mailto:alimprasaja@gmail.com), <sup>5</sup>[kadekjuni96@gmail.com](mailto:kadekjuni96@gmail.com)

**Abstrak.** Home state monitoring penting bagi pemilik rumah. Karena di Indonesia pencurian dan kebakaran adalah hal yang wajar. Hal tersebut disebabkan oleh kelalaian pemilik rumah. Oleh karena itu, dibuatlah sistem pemantauan keamanan rumah untuk meminimalisir pencurian dan kebakaran rumah. Pada penelitian ini dibuat sistem pemantauan keamanan rumah dengan menggunakan sensor pendeteksi gerak manusia atau sensor PIR (Passive Infrared Receiver), sensor suhu, detektor nyala api, buzzer, dan pompa. Sensor PIR digunakan untuk mendeteksi pencuri sehingga buzzer dapat berbunyi. Sensor suhu dan detektor api digunakan untuk mendeteksi kebakaran kemudian pompa akan memadamkan api. Sistem tersebut kemudian diintegrasikan dengan perangkat HP android, sehingga pemilik rumah dapat memantau rumah dimanapun dan kapanpun. Dari hasil pengujian, sensor PIR dapat mendeteksi pergerakan manusia dengan jarak 3,4 meter dan sudut 90o. Sensor suhu dan detektor nyala masing-masing mendeteksi suhu dan titik api dengan jarak maksimum 25 cm

**Kata Kunci:** Home state monitoring, Passive Infrared Receiver (PIR), sensor suhu, detector api, Android System

**Abstract.** A home state monitoring is important for homeowners. Because in Indonesia, theft and fire are common occurrences. This is caused by the negligence of homeowners. Therefore, home security monitoring systems are made to minimize theft and house fires. In this study, home security monitoring systems were made using human motion detection sensors or PIR (Passive Infrared Receiver) sensors, temperature sensors, flame detectors, buzzers, and pumps. The PIR sensor is used to detect thieves so buzzer can sound. The Temperature sensor and flame detector are used to detect fires then the pump will extinguish the fire. The system is then integrated with android HP devices, so homeowners can monitor the home wherever and whenever. From the test results, PIR sensor can detect human movement with a distance of 3.4 meters and the angle is 90o. The Temperature sensors and flame detectors detect temperatures and hotspots with a maximum distance of 25 cm, respectively.

**Keywords:** Home state monitoring, Passive Infrared Receiver (PIR), temperature sensor, flame detector, Android System

### 1. Introduction

The home security system is a very important device. Because home security systems can provide security by monitoring the state of the house. The ATMEGA 328 home security system is designed to monitor the state of the house(www.microchip.com). The goal is to monitor objects, detect hotspots, and detect temperatures in the room so that the room does not occur theft and fire when the house is quiet (Kaur, Inderpreet, 2010) (Azid, Sheikh Izzal, and Sushil Kumar., 2011) (Mukhopadhyay, Subhas C., Anuroop Gaddam, and Gourab S. Gupta., 2008). The sensor used is a Passive Infrared Receiver (PIR) sensor, temperature sensor, and the flame detector. In this research, this security system is also equipped with remote monitors using android, so that home owners can monitor the condition of the house directly. Then, this system is also equipped with an alarm. The alarm will sound when there is a thief coming in and a fire occurs. Figure 1 is the overall block diagram of the home security monitoring system.

### 2. Literature Review

#### 2.1. Microcontroller And Sensors

The microcontroller used is ATMEGA328 as shown in Figure 2. ATMEGA328 has 16 digital pins (6 of which can be used as PWM outputs), 6 analog inputs, a 16 MHz crystal oscillator, a USB connection,

a power jack, an ICSP header, and a reset button(www.atmel.com). ATmega328 contains everything needed to support the microcontroller, easily connect it to a computer with a USB cable or supply it with an AC adapter to DC or use a battery. Passive Infrared Receiver (PIR) sensors, temperature sensors, and the flame detector are used in this paper.

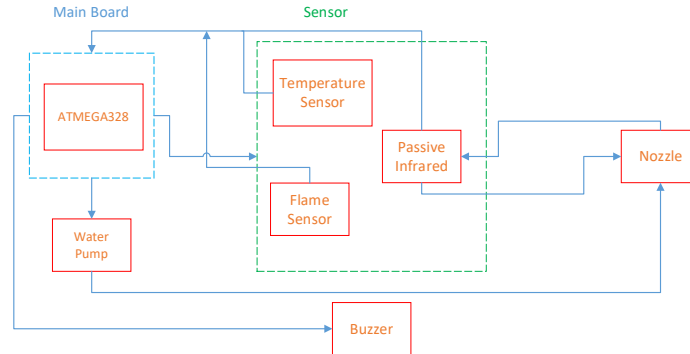

Figure 1. Overall block diagram of the home security monitoring system

(PCINT14/RESET) PC6	1	28	PC5 (ADC5/SCL/PCINT13)
(PCINT16/RXD) PD0	2	27	PC4 (ADC4/SDA/PCINT12)
(PCINT17/TXD) PD1	3	26	PC3 (ADC3/PCINT11)
(PCINT18/INT0) PD2	4	25	PC2 (ADC2/PCINT10)
(PCINT19/OC2B/INT1) PD3	5	24	PC1 (ADC1/PCINT9)
(PCINT20/XCK/T0) PD4	6	23	PC0 (ADC0/PCINT8)
VCC	7	22	GND
GND	8	21	AREF
(PCINT6/XTAL1/TOSC1) PB6	9	20	AVCC
(PCINT7/XTAL2/TOSC2) PB7	10	19	PB5 (SCK/PCINT5)
(PCINT21/OC0B/T1) PD5	11	18	PB4 (MISO/PCINT4)
(PCINT22/OC0A/AIN0) PD6	12	17	PB3 (MOSI/OC2A/PCINT3)
(PCINT23/AIN1) PD7	13	16	PB2 (SS/OC1B/PCINT2)
(PCINT0/CLKO/ICP1) PB0	14	15	PB1 (OC1A/PCINT1)

Figure 2. ATMEGA328[6]

### 2.2. Passive Infrared (PIR)

PIR sensor is a sensor that does not emit infrared light but receives infrared radiation from the outside(Moghavvemi, M., and Lu Chin Seng., 2004) as shown in Figure 3. This sensor will compare the infrared beam of an object that is received every time unit, so that if there is the movement then this sensor reading will change. The beam receiver of this object is the IR Filter. The IR Filter functions to filter the wavelength of passive infrared light between 8-14 micrometers so that the wavelengths produced from the human body that range from 9-10 micrometers can be detected by the sensor.

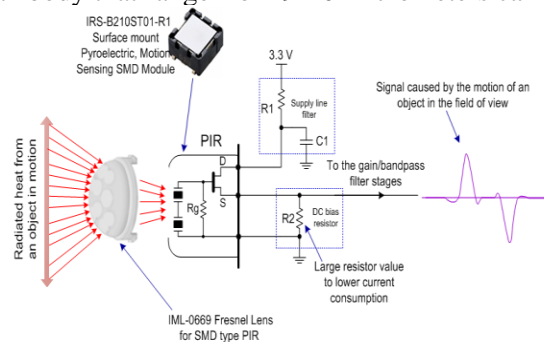

Figure 3. Passive Infrared (PIR)[7]

### 2.3. Temperature Sensor

In this paper, the temperature sensor used is LM35 as shown in Figure 4. This sensor has a vulnerable temperature between -55 to +150 ° C. This sensor also operates at a voltage of 4 to 30 V. LM35 sensor

calibration is done by comparing the measurement results with the thermometer on the market. The sensor's linearity and accuracy are  $+10 \text{ mV} / ^\circ\text{C}$  and  $0.5 ^\circ\text{C}$ .



Figure 4. LM35 Sensor

#### 2.4. Sensor Flame

Flame sensor or flame detector is an optical device used to detect flames. Figure 5 is a flame sensor for infrared or ultraviolet radiation from a burning flame. Flame sensors work at wavelengths of 760 nm - 1100 nm, and specifications for this type of flame sensor have a detection distance of less than 1 m with a detection angle of  $60^\circ\text{C}$ .



Figure 5. Flame sensor

#### 2.5. ESP8266 Wi-Fi Module

This Wi-Fi module is a System on Chip (SoC) which is equipped with a TCP / IP protocol stack that has been integrated so that the microcontroller can access Wi-Fi networks. The AT command is a command to connect the microcontroller with Wi-Fi. This module has strong onboard storage and processing capabilities. This capability can be used to integrate sensors and other devices through GPIO in this module. So Figure 6. is an ESP8266 module for solutions from IoT (Internet of Things).



Figure 6. ESP8266 module

### 3. Methodology

In this paper, codevision AVR is used for programming and implementation. The programming used in codevision AVR is C programming. The program work steps for this paper are :

1. Start is the first step in starting a program
2. The next step is to initialize to the Local Server
3. After that, see if the Android device is connected to the Local Server
4. The next process reads the data in the form of an output from the PIR sensor.
5. Data that has been displayed to the user. Then an action can be given. Whether there is movement or not.
6. The next process is the buzzer automatically sounds when there is a human movement
7. The next step is to read the flame sensor for fire detection.
8. Then read the temperature sensor. Is the temperature more than  $32^\circ\text{C}$ .
9. The system will automatically activate the water pump after a temperature of more than  $32^\circ\text{C}$  and the flame sensor detects fire.

## 10. Repeat from step 3 to 9.

**Code 1. Source code in C programming language**

```

1. For the sensor testing program :
int suhu = A0; int nilaisuhu= 0; int api =3;
int nilaiapi=0;
int motion= 2;
int nilaimotion=0;
int buzzer =4; int relay1=5; int a;

void setup(){ Serial.begin(9600);
pinMode (buzzer,OUTPUT);
pinMode(relay1, OUTPUT);
}

void loop(){
nilaisuhu = analogRead(nilaisuhu); Serial.println(nilaisuhu);
delay(100);
nilaiflame = digitalRead(api);
nilaimotion = digitalRead(motion);
nilaisuhu = nilaisuhu * 0.488; Serial.println(nilaisuhu); delay(100);
if (nilaimotion==1)
{digitalWrite(buzzer,HIGH);
if (nilaiflame==0)
{ digitalWrite(relay1,HIGH); a=1;}
else
{ digitalWrite(relay1,LOW); a=0;
delay(100);}
}
else
{digitalWrite(buzzer,LOW);
}
}

2. For the microcontroller communication program to android :
#include <SoftwareSerial.h>
#include <stdlib.h>

int ledPin = 13; int lm35Pin = 0; int motion = 2;
int nilaimotion =0;
int flame =3;
int nilaiflame=0;
int buzzer =4; int relay1=5; int a;
String apiKey = "BA67YSIJU014SMTZ"; SoftwareSerial ser(10, 11); // RX, TX

void setup()
{pinMode(ledPin, OUTPUT); pinMode(buzzer, OUTPUT); pinMode(relay1, OUTPUT);
Serial.begin(115200); ser.begin(115200); ser.println("AT+RST");
}

void loop()
{digitalWrite(ledPin, HIGH);
delay(200);
digitalWrite(ledPin, LOW); nilaimotion = digitalRead(motion);
Serial.println(nilaimotion); delay(200);
int val = 0;
for(int i = 0; i < 10; i++) {
val += analogRead(lm35Pin);
delay(100);
nilaimotion = digitalRead(motion);
nilaiflame = digitalRead(flame);
}
float temp = val*50.0f/1023.0f;
char buf[16];

```

```

String strTemp = dtostrf(temp, 4, 1, buf); Serial.print("Suhu = ");
Serial.println(strTemp);
Serial.print("Nilai Motion = "); Serial.println(nilaimotion);
Serial.print("Nilai Flame = "); Serial.println(a);
if (nilaimotion==1){ digitalWrite(buzzer,HIGH); if (nilaiflame==0) {
digitalWrite(relay1,HIGH);
a=1;
}
else { digitalWrite(relay1,LOW); a=0;
delay(100);
}
else {
digitalWrite(buzzer,LOW);
}
String cmd = "AT+CIPSTART=\"TCP\", \"";
cmd += "184.106.153.149"; // api.thingspeak.com cmd += "\",80";
ser.println(cmd);
if(ser.find("Error")){ Serial.println("AT+CIPSTART error"); return;
}
String getStr = "GET /update?api_key=";
getStr += apiKey;
getStr += "&field2=";
getStr += String(nilaimotion);
getStr += "&field1="; getStr += String(strTemp); getStr += "&field3=";
getStr += String(a);
getStr += "\r\n\r\n";
cmd = "AT+CIPSEND=";
cmd += String(getStr.length());
ser.println(cmd);
if(ser.find(">")){
ser.print(getStr);
}
else
{ ser.println("AT+CIPCLOSE"); Serial.println("AT+CIPCLOSE");
}
delay(1000);
}

```

#### 4. Hardware Subsystem

In this research, the ATmega328 microcontroller was used. This system requires 3 inputs (PIR sensor, temperature sensor, and flame detector) and 2 outputs that are connected to the relay attached to the buzzer and water pump as shown in Figure 7. The process of designing electronic circuits used is regulated using the eagle program. To connect ESP8266 with the microcontroller, Rx and Tx pins are used for serial communication on the microcontroller. Table 1 is a pin configuration of the microcontroller.

**Table 1. Setting of Microcontroller Pin.**

Microcontroller Pin	Hardware
A	Temperature sensor
0	PIR sensor
D	Flame sensor
2	Buzzer
D	Relay

#### 5. Results

PIR sensor testing is carried out using two different objects, namely the human body and animals (cats). If motion is detected it will produce High, whereas if movement is not detected it will produce Low. PIR sensor testing results can be seen in table 2, 5, and 6. In the range of 100 cm - 340 cm the sensor still detects movement while at a distance of more than 340 cm, the sensor

cannot detect movement. This PIR sensor is able to detect horizontally and vertically with a maximum angle of 90°. With a digital output voltage, the value of 0 digital sensor voltage is 0 volts and at a value of 1 digital sensor voltage of 3.2 volts. The temperature sensor is focused on monitoring the temperature of the room by converting the ADC value into units of temperature degree Celsius. The results of temperature sensor testing can be seen in table 3. Flame sensor testing is done by turning on the fire point with a range of 1 cm - 25 cm. The maximum limit of the flame sensor can detect at a distance of 25 cm fire. The results of the flame sensor testing can be seen in table 4.

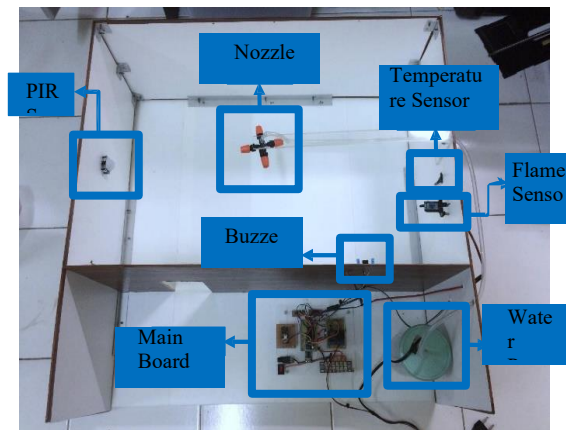

Figure 7. Prototype of the home security monitoring system

For the overall results of the system that has been made, data collection is done to determine the effectiveness of the software and hardware that has been made so that the system of this tool can work according to the concept. To test the success of the system that has been made, data collection is needed as shown in table 6.

Android-based home security monitoring system has an initial view as in Figure 8. In table data 2, 3 and 4 the previous sensor experiment can be seen from the results of the suitability of the data interface that entered Android in Figure 9, 10, and 11.

Table 2 Testing of PIR sensors

Experiment	Position		Sensor output (Volt)
	Distance (cm)	Angel (°)	
1	50 cm	30°	0 volt
2	100 cm	40°	0 volt
3	150 cm	45°	3,2 volt
4	200 cm	60°	3,2 volt
5	250 cm	75°	3,2 volt
6	300 cm	90°	3,2 volt
7	320 cm	100°	3,2 volt
8	340 cm	125°	3,2 volt
9	350 cm	135°	3,2 volt
10	360 cm	140°	0 volt

Table 3 Testing of temperature sensors

Experiment	Room temperature (°C)	Sensor output (mV)
1	30,76 °C	300 mV
2	31,25 °C	313 mV
3	33,69 °C	336 mV

4	48,83 °C	482 mV
5	49,32 °C	490 mV
6	52,42 °C	523 mV
7	56,64 °C	560 mV
8	59,31 °C	592 mV
9	60,06 °C	602 mV
10	60,55 °C	608 mV

**Table 4 Testing flame sensors**

Experiment	Yes / No Fire	Distance (cm)	Sensor output (mV)
1	No	1 cm	0 mV
2	Yes	5 cm	310 mV
3	No	10 cm	0 mV
4	Yes	12 cm	310 mV
5	No	14 cm	0 mV
6	Yes	16 cm	310 mV
7	No	18 cm	0 mV
8	Yes	20 cm	310 mV
9	Yes	22 cm	310 mV
10	Yes	25 cm	310 mV

**Table 5 Testing of device when PIR sensors detect human movement**

Object	Movement (Y/N)	Distance (cm)	Buzzer (sound)
Human	No	100 cm	No
Human	Yes	150 cm	Active
Human	No	200 cm	No
Human	Yes	250 cm	Active
Human	Yes	300 cm	Active
Human	Yes	340 cm	Active
Human	No	350 cm	No
Human	Yes	400 cm	No

**Table 6 Testing of device when PIR detects animal movements (Cats)**

Object	Movement (Y/N)	Distance (cm)	Buzzer (sound)
Cat	Yes	10 cm	Active
Cat	No	50 cm	No
Cat	Yes	100 cm	Active
Cat	Yes	120 cm	Active
Cat	No	140 cm	No
Cat	Yes	160 cm	Active
Cat	Yes	180 cm	No
Cat	Yes	200 cm	No

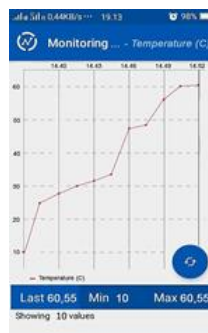

**Figure 8. Temperature Sensor Data in android**



**Figure 9. PIR sensor data in android**



**Figure 10. Flame sensor data in android**

## 6. Conclusions

Android-based Home Monitoring System consisting of a global network system. This system utilizes the ThinkSpeak application as a monitoring medium for the results of the temperature sensor to monitor temperature, PIR sensor to monitor the presence or absence of movement inside the house with the appearance of binary numbers that are 1 and 0, 1 for movement detected and 0 for movement undetected. Likewise with a flame sensor, 1 for there are hotspots and 0 for no hotspots. And to receive sensor data, it takes about 10 seconds.

## References

<http://www.microchip.com/>

Kaur, Inderpreet., 2010, "Microcontroller based home automation system with security." *International Journal of Advanced Computer Science and Applications (IJACSA)* 1.6: 60-65.

Azid, Sheikh Izzal, and Sushil Kumar., 2011, "Analysis and performance of a low cost SMS based home security system." *International Journal of Smart Home* 5, no. 3.

Ab-Rahman, Mohammad Syuhaimi, Aswir Premadi, and Kasmiran Jumari., 2008, "Remote monitor and control based access control system using PIC microcontroller." *IJCSNS* 8, no. 11: 423

Mukhopadhyay, Subhas C., Anuroop Gaddam, and Gourab S. Gupta., 2008, "Wireless sensors for home monitoring-a review." *Recent Patents on Electrical Engineering* 1, no. 1: 201-1.

[http://www.atmel.com/Images/Atmel-8271-8-bit-AVR-Microcontroller-ATmega48A-48PA-88A-88PA-168A-168PA-328-328P\\_datasheet\\_Summary.pdf](http://www.atmel.com/Images/Atmel-8271-8-bit-AVR-Microcontroller-ATmega48A-48PA-88A-88PA-168A-168PA-328-328P_datasheet_Summary.pdf)